

# CIMON Xpanel

In Korean & English

- CM-eXT2-07-R/C(H)-DE/DF
- CM-eXT2-10W-R/C(H)-DE/DF
- CM-eXT2-12W-R/C(H)-DE/DF
- CM-eXT2-15W-R/C(H)-DE/DF

# Xpanel

CIMON-Xpanel은 전 기종 Ethernet 통신을 지원하며 Embedded Linux 기반의 고성능의 터치패널 HMI로 TFT LCD를 통한 고품격의 색 표현 능력과 고해상도를 통한 세밀한 정보 표시 능력을 제공합니다. 또한 대용량의 저장공간을 이용한 대규모 프로젝트의 운용 능력을 가진 모니터링 장치입니다.

필수 안전 수칙 .....	03
구성품 확인하기 .....	07
1. 제품 치수 .....	08
2. 인터페이스 .....	12
3. 설치 .....	16
4. 결선 및 전원 주의사항 .....	18
5. 접지 주의 사항 .....	19
6. 제품 사양 .....	20
7. 환경 사양 .....	25
8. Xpanel 프로젝트 다운로드 방법.....	26
9. 품질보증규정.....	31

- 사용하기 전 반드시 본 User Manual을 잘 읽어주시기 바랍니다.
- 제품 모델에 따라 본 매뉴얼 내용이 다를 수 있으며 예고없이 변경될 수 있습니다.
- 이 기기는 업무용(A급)으로 전자파적합등록을 한 기기이오니 판매자 또는 사용자는 이 점을 주의하시기 바라며, 가정 외의 지역에서 사용하는 것을 목적으로 합니다.

# 필수 안전 수칙



경고

## 시스템 설계

1. Xpanel 과 운전자의 안전을 해칠 수 있는 그래픽 오브젝트를 작성하지 마십시오.  
Xpanel 이 파손되어 출력 신호가 ON 또는 OFF 상태로 남아있게 되면 중대한 사고를 일으킬 수 있습니다. 중대한 사고 발생 시 외부에 비상 정지 스위치를 구현하여 비상 정지할 수 있도록 설계하십시오.
2. Xpanel 을 운전자의 상해, 장비의 파손, 생산중단 등 심각한 문제를 일으키는 중요한 정보를 경고하는 장비로 사용하지 마십시오. 고장이 나더라도 수동으로 시스템을 조작 가능하도록 설계하십시오.
3. Xpanel 은 극히 높은 안정성과 신뢰성이 요구되는 비행기 제어장치, 항공우주 장비, 중압갑중의 중요 데이터를 전송하는 장치, 원자력 제어 장치, 의료용 생명 유지 장치 등과의 사용은 적합하지 않습니다.
4. Xpanel 을 기차, 자동차, 선박 등의 교통수단, 재난 및 범죄 예방 장치, 다양한 안전장치, 생명유지장치가 아닌 의료 장비 등과 함께 사용할 경우, 적절한 정도의 신뢰성과 안정성을 확보하기 위하여, 예비용 또는 고장대비용 설계가 필요합니다.
5. Xpanel 의 LCD 백라이트 수명이 다하여 화면이 나오지 않는 경우에도 Xpanel 은 여전히 동작 중입니다. 운전자가 동작 상태를 인지하지 못하고 터치패널을 만진다면, 장치가 잘못된 동작을 할 수 있습니다. 따라서 사람의 부상을 막고 장치의 파손을 막는 비상정지 스위치와 같은 안전 장치를 제어하기 위해 제품의 그래픽 오브젝트를 사용하지 마십시오.

## 분해 및 개조 금지

1. Xpanel 을 분해하지 마십시오. Xpanel 내부에 높은 전압이 흐르고 있기 때문에 분해하면 감전될 수 있습니다.
2. Xpanel 을 개조하지 마십시오. 개조된 Xpanel 은 화재나 감전을 일으킬 수 있습니다.

## 필수 안전 수칙



경고

### 인화성 물질 접근 제한

Xpanel 을 인화성 기체가 있는 장소에서 사용하지 마십시오. 인화성 기체가 있는 장소에서 조작하면 폭발을 일으킬 수 있습니다.

### 설치

1. 모든 케이블 커넥터들을 Xpanel 에 단단히 연결하십시오. 느슨하게 연결하면 잘못된 입력 또는 출력이 발생할 수 있습니다.
2. Xpanel 의 단자대의 나사를 조일 때, 토크는 0.5~0.6N·m 가 적당합니다. 나사를 단단히 조이지 않으면 단락, 화재, 제품 고장을 일으킬 수 있습니다.
3. 금속 가루와 전선 조각이 Xpanel 안으로 떨어지지 않게 주의하십시오. 금속 가루와 전선 조각은 화재, 제품고장, 오작동을 일으킬 수 있습니다.
4. 제품을 반드시 수직으로 세워 설치하여 주시기 바랍니다.

### 유지보수 - 배터리 교환

Xpanel 은 내부시계를 작동하기 위하여 리튬 배터리를 사용합니다. 배터리를 교환 중 잘못 장착되면 배터리가 폭발할 수 있습니다. 사고를 방지하기 위해 배터리를 직접 교환하지 마십시오. 배터리를 교환해야 할 경우 Xpanel 공급자에게 연락하기 바랍니다.

### LCD 파손 시 대처 요령

LCD 패널에는 강력한 자극 물질이 포함되어 있습니다. 만약 어떤 이유에서건 패널이 파손되어 LCD 의 액체가 신체부위에 닿으면, 반드시 흐르는 물에 15 분간 닦으십시오. 만약 LCD 의 액체가 눈에 들어가면, 눈에 흐르는 물을 흘려서 15 분간 닦고 의사에게 진찰을 받으십시오.

## 필수 안전 수칙



### 결선

1. 전원 분리 여부 확인
  - Xpanel 에 결선을 할 때 감전을 막기 위하여 Xpanel 의 전원이 분리된 것을 반드시 확인하십시오.
2. 입력 전압 확인
  - Xpanel 에 허용된 범위를 넘는 전압을 인가하지 마십시오. 허용된 범위를 넘는 전압을 인가하면, PC 에 화재나 감전을 일으킬 수 있습니다.
  - Xpanel 은 과전압 범주 II 에 속합니다.
3. 접지 선 연결 주의
  - Xpanel 의 접지 선을 다른 장비의 접지 선들과 분리하여 접지하십시오.
  - 접지선 끼리 너무 가깝게 위치하면, 감전이나 제품 고장을 일으킬 수 있습니다.
  - 반드시 접지 저항이 100 Ω 이하의 2mm<sup>2</sup> 보다 굵은 전선을 사용하여 각국의 설비 표준을 준수하십시오.
4. 외부 케이블 결선 시 주의
  - 정격전압과 터미널 배치가 지정된 범위인지 확인하고, Xpanel 을 정확하게 결선하십시오.
  - 공급되는 전압이 정격과 다르거나, 결선 또는 접지를 잘 못하면, 화재나 제품 고장을 일으킬 수 있습니다.

### 제품 사용 주의 사항

1. 터치 패널을 단단한 물체로 때리거나, 너무 세게 누르지 마십시오. 터치패널과 LCD 가 손상 될 수 있습니다.
2. Xpanel 을 허용된 온도를 초과하는 장소에 설치하지 마십시오. Xpanel 이 파손되거나 수명이 단축될 수 있습니다.
3. Xpanel 의 뒤쪽 송풍구를 막지 마십시오.
4. Xpanel 을 온도변화가 크거나 급격한 장소에서 사용하지 마십시오. 제품 내부에서 이슬이 맺혀 제품이 파손될 수 있습니다.

## 필수 안전 수칙

### ⚠ 경고

5. 물, 액체, 금속, 전하를 띤 티끌이 Xpanel 내부로 들어가지 않도록 하십시오. Xpanel 이 파손되거나 감전될 수 있습니다.
6. Xpanel 을 직사광선에 비치거나, 먼지가 많거나, 더러운 곳에서 사용 또는 보관하지 마십시오.
7. Xpanel 을 진동이 심한 곳에서 사용 또는 보관하지 마십시오.
8. Xpanel 을 화학물질 또는 산화물질이 증발되거나 공기 중에 포함된 장소에서 사용 또는 보관하지 마십시오.
9. Xpanel 을 페인트 시너나 솔벤트 등으로 닦지 마십시오.
10. LCD 를 직사광선이 비치는 장소에서 보관하거나 조작하지 마십시오. 태양의 자외선에 의해 LCD 표시 품질이 저하될 수 있습니다.
11. 허용치보다 온도가 낮은 장소에서 Xpanel 을 보관하면 LCD 의 액체가 응결되어 LCD 가 파손될 수 있습니다. 거꾸로 허용치보다 온도가 높은 장소에서 Xpanel 을 보관하면 액체가 등방성을 띠고 환원되지 않을 수 있습니다. LCD 패널을 반드시 허용된 온도 범위에서 보관하십시오.
12. Xpanel 의 전원을 끄고 전원을 다시 켤 때까지 반드시 몇 초 동안 기다리십시오. 너무 빨리 전원을 켜면 Xpanel 이 정상적으로 시작하지 않을 수 있습니다.
13. 예상치 않은 사고에 대비하여 Xpanel 프로젝트를 정기적으로 백업하십시오.

## 제품 사용 주의 사항

이 제품이 폐기될 때 산업폐기물류에 대하여 국가에서 정한 법규에 따라 처리되어야 합니다.

## 구성품 확인하기

- Xpanel 제품의 구성품은 다음과 같습니다. Xpanel을 사용하기 전에 아래의 구성품이 모두 있는지 확인하시기 바랍니다.
- 설치안내서에 표시된 그림은 설명의 이해를 돕기 위한 것으로 실물 크기와 다를 수 있습니다.

- 본체 - 1 EA



- 고정 연결 고리 - 4 EA (7"), 10 EA (10"/12"/15")

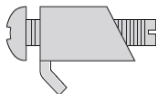

- 5핀 커넥터 (RS 422/485) - 1 EA

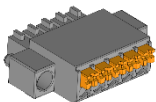

- 전원플러그 - 1 EA

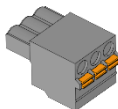

- 설치안내서 - 1 EA



※ 본 제품은 품질을 위해 주의하여 포장하였습니다. 하지만 구성품이 파손되거나 누락된 것을 발견하면, Xpanel 공급자에게 즉시 연락하시기 바랍니다.

# 1. 제품치수

Unit: mm

· eXT2-07

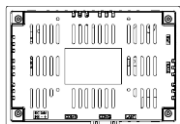
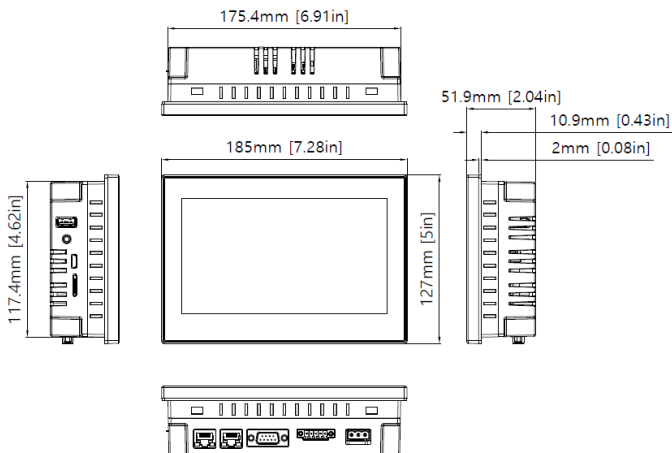

eXT2-07-R-DE

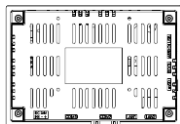

eXT2-07-R-DF

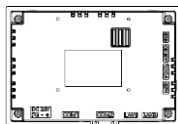

eXT2-07-C/CH/RH-DF

# 1. 제품치수

Unit: mm

Korean

· eXT2-10W

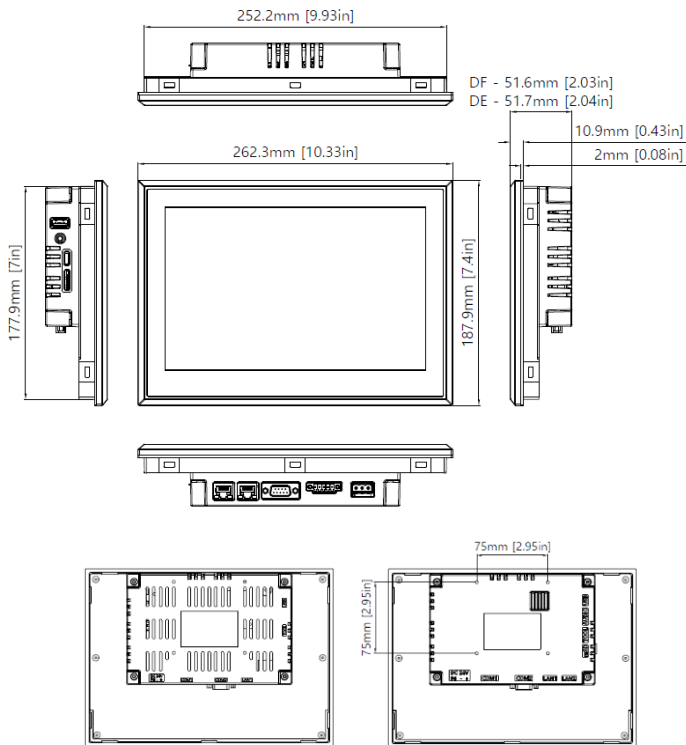

eXT2-10W-□□-DE

eXT2-10W-□□-DF

# 1. 제품치수

Unit: mm

· eXT2-12W

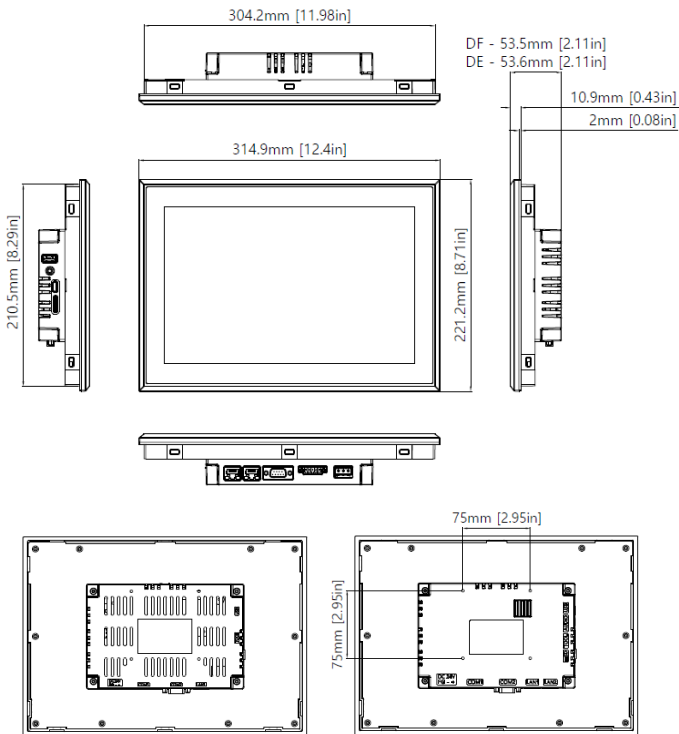

eXT2-12W-□□-DE

eXT2-12W-□□-DF

# 1. 제품치수

Unit: mm

Korean

· eXT2-15W

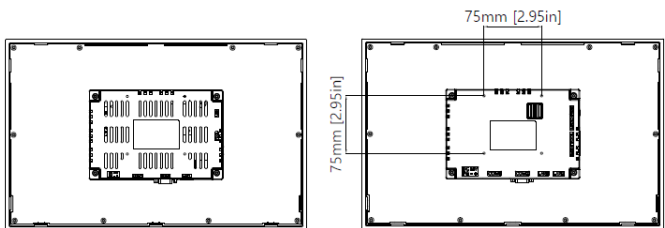
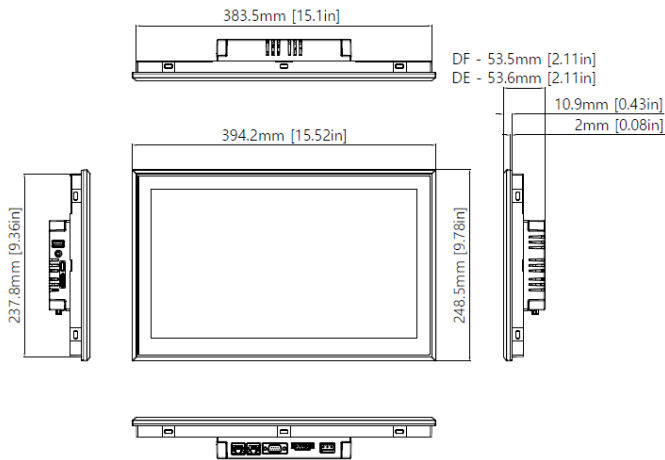

eXT2-15W-□□-DE

eXT2-15W-□□-DF

## 2. 인터페이스

### · eXT2-□□-□□-DE

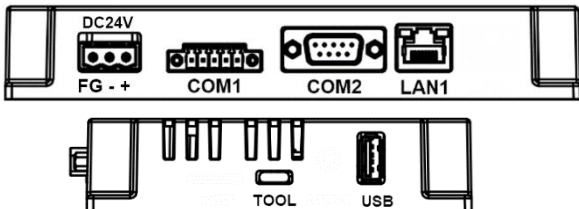

### · eXT2-□□-□□-DF

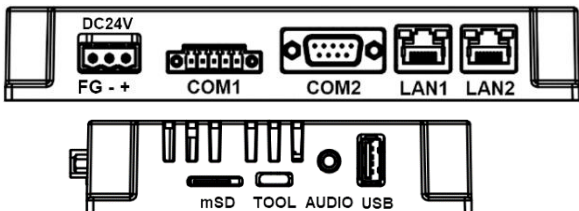

Name	Description
mSD	Micro SD Socket
TOOL	USB Device (USB 2.0 Type-C)
AUDIO	Audio Out (3.5mm Stereo)
USB	USB Host (USB 2.0 Type-A)

## 2. 인터페이스

### ● COM1: RS-422/485

이 커넥터는 Xpanel과 장비가 RS-422 또는 RS-485 규격으로 통신하기 위해 사용됩니다.

Connector	Pin No.	Name	Description
	1	RDB	Receive Data B
	2	RDA	Receive Data A
	3	GND	Ground
	4	SDB	Send Data B
	5	SDA	Send Data A



- RS-485 결선일 경우 SDA와 SDB만 연결하십시오.
- RS-485는 Auto Toggle로 동작됩니다.
- 상대기기가 절연되지 않는 경우 RS-422 회로가 손상되는 위험을 줄이기 위하여 반드시 3번 GND를 연결하십시오.

## 2. 인터페이스

### ● COM2 : RS-232C

이 커넥터는 PC와 장비가 RS-232C 규격으로 통신하기 위해 사용됩니다.

2, 3, 5, 7, 8번 핀만 사용할 수 있습니다.

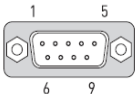
Connector	Pin No.	Name	Description
	1		
	2	RD	Receive Data
	3	TD	Transmit Data
	4		
	5	SG	Signal Ground
	6		
	7	RTS	Request To Send
	8	CTS	Clear To Send
	9		



- USB를 상시 통신포트로 사용하는 것은 권장하지 않습니다. 이 때 발생한 문제는 품질을 보증할 수 없습니다.
- Xpanel의 시리얼 포트는 절연되어 있지 않습니다.
- Xpanel의 내부에서 SG(Signal Ground)와 FG(Frame Ground)는 연결되어 있습니다.
- 외부 기기와 Xpanel의 SG를 연결하는 경우 회로가 단락 되지 않도록 주의하십시오.

## 2. 인터페이스

### ● Ethernet

이 인터페이스는 Xpanel과 장비가 Ethernet규격으로 통신하기 위해 사용합니다. RJ45 커넥터의 핀 번호와 케이블 제작은 그림을 참고하십시오.

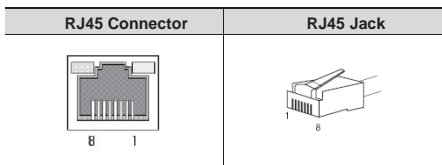

### Direct Cable: Host ↔ HUB

Cable	No	Color	Color	No	Cable
	1	Orange/W	Orange/W	1	
	2	Orange	Orange	2	
	3	Green/W	Green/W	3	
	4	Blue	Blue	4	
	5	Blue/W	Blue/W	5	
	6	Green	Green	6	
	7	Brown/W	Brown/W	7	
	8	Brown	Brown	8	

### Crossover Cable: Host ↔ Host

Cable	No	Color	Color	No	Cable
	1	Orange/W	Green/W	1	
	2	Orange	Green	2	
	3	Green/W	Orange/W	3	
	4	Blue	Blue	4	
	5	Blue/W	Blue/W	5	
	6	Green	Orange	6	
	7	Brown/W	Brown/W	7	
	8	Brown	Brown	8	

### 3. 설치

- 패널의 Xpanel 설치 부분을 절단하고 Xpanel을 앞에서 장착합니다. 절단 크기는 다음 그림을 참고하십시오.

Unit: mm

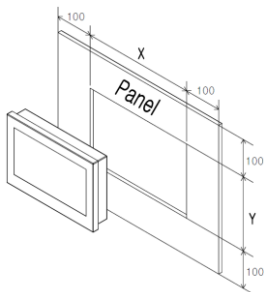

	X	Y
CM-eXT2-07	177	119
CM-eXT2-10W	254	179
CM-eXT2-12W	305	212
CM-eXT2-15W	385	239

- 패널의 안쪽에서 고정 연결 고리를 이용하여 고정합니다. Xpanel의 고정 슬롯에 연결고리를 걸고 드라이버로 조입니다.

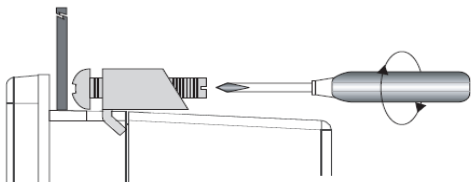

- 나사를 너무 세게 조이면 Xpanel의 케이스가 파손됩니다.
- 토크는 0.5 N·m가 적당합니다.
- 설치할 패널의 두께에 따라 원하는 방수 정도를 달성하기 위하여 고정 연결고리의 수를 늘릴 필요가 있습니다.

### 3. 설치

- 패널의 설치 시 기기의 성능 저하 방지 및 안전한 사용을 위해 본체 후면, 용기와 각 벽면과의 간격은 100mm 이상 유지하여 주시기 바랍니다.

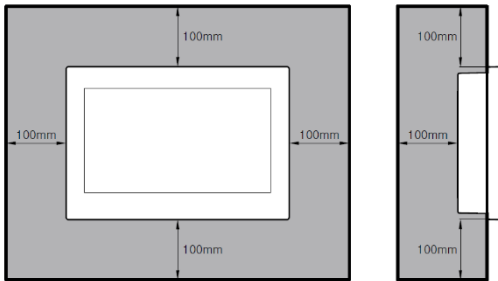

- VESA 마운트에 제품 설치 시, 마운트 및 나사 크기는 다음 그림을 참고하십시오.

\* VESA 마운트 지원모델

- CM-eXT2-07-C□-□□
- CM-eXT2-07-RH-DF
- CM-eXT2-10W-□□-DF
- CM-eXT2-12W-□□-DF
- CM-eXT2-15W-□□-DF

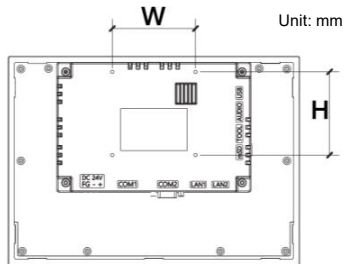

	H	W	Screw
VESA	75	75	M4 Max. 9

## 4. 결선 및 전원 주의사항

### ⚠ 경고

전원을 연결할 경우 아래의 절차를 따르십시오.

1. Xpanel의 전원선을 연결할 때, 감전을 방지하기 위하여, 차단기를 통해 Xpanel의 전원부가 완전히 꺼진 것을 확인하십시오.
2. 제품의 정격전압을 확인하십시오.
3. 전원선이 빠지지 않도록 주의하십시오.

전원선을 Xpanel에 연결할 때 다음 사항을 특히 주의하십시오.

1. 사용할 전원의 전압이 Xpanel의 정격전압을 초과하면 전압트랜스를 사용하십시오.
2. 전원과 접지 사이에 노이즈가 낮은 전원을 사용하십시오. 과도한 노이즈가 있다면 노이즈 감쇄 트랜스를 연결 하십시오.
3. Xpanel 전원선은 고전압, 고전류의 전력선과 같이 묶거나 같이 두어서는 안됩니다.
4. 전력 서지에 대비하여 서지 업서버를 연결하십시오.
5. 노이즈를 줄이기 위해 전원선은 가능한 짧게 하십시오.
6. 제품의 전원 입력 시 반드시 제품에 표시된 극성(+, -)을 확인하고 연결하여 주십시오. 극성이 잘못될 경우 제품의 고장이나 화재의 원인이 될 수 있습니다.

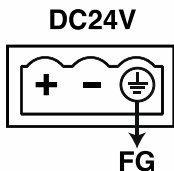

- 핀터미널의 전선이 바르게 연결되었는지 확인하십시오.
- 나사를 조일 때 토크는 0.5~0.6 N·m가 적당합니다.
- Wire Range : AWG 14 - 26 SOL/STR, Wire Type : Cu

## 5. 접지 주의사항

- 제품의 내부에서 S.G(Signal Ground)와 F.G(Frame Ground)는 연결되어 있습니다.
- F.G 단자를 접지할 경우 다른 기기와 분리하여 접지하십시오.
- Xpanel 의 SG 와 상대기기의 SG 를 연결할 경우 단락된 회로가 생기지 않도록 주의하십시오.
- F.G 단자는 입력 전원 쪽에 있습니다. 커넥터의  표시된 부분에 접지선을 연결하십시오.

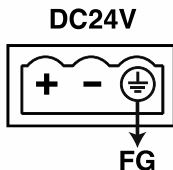

- F.G 단자를 접지할 경우 다른 기기와 분리하여 접지하십시오. (아래 그림 참고)

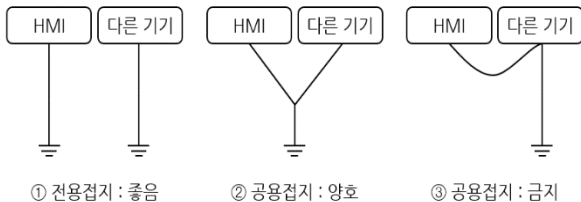

- 접지에 의해 동작 이상이 발생하는 경우, F.G 단자를 접지와 분리하십시오.

## 6. 제품 사양

### CM - eXT2 - 10W - RH - D F

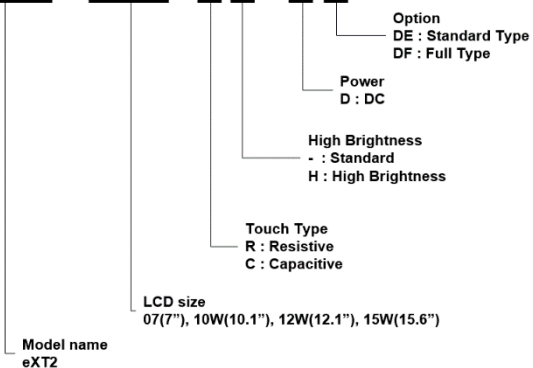

	Ethernet	Audio	MicroSD slot
- DE	1 port	X	X
- DF	2 port	O	O

## 6. 제품 사양

### ● eXT2-07

Model	CM-eXT2-07-R-DE	CM-eXT2-07-C-DE	CM-eXT2-07-R-DF	CM-eXT2-07-C-DF	CM-eXT2-07-RH-DF	CM-eXT2-07-CH-DF
Enclosure	Front / Rear: Plastic	Front / Rear: Aluminum	Front / Rear: Plastic	Front / Rear: Aluminum		
Display	7 inch Wide TFT Color					
Colors	16.7M					
Resolution	1024 x 600 WSVGA (128:75)					
Effective Display Area	154.21 (H) x 85.92 (V) mm					
PPI	170					
Backlight Type	LED					
Luminance	1,000 cd/m <sup>2</sup>			1,200 cd/m <sup>2</sup>		
Contrast Ratio	1000:1					
Backlight Life	50,000 hours					
Touch Panel	4 wire Resistive	10 points Capacitive	4 wire Resistive	10 points Capacitive	4 wire Resistive	10 points Capacitive
Touch Panel Accuracy	Active Area Length (X) ±2%, Width (Y) ±2%					
Display Orientation	Landscape (Standard, 180°), Portrait (90°, 270°)					
Memory	2GB LPDDR4					
Storage	8GB eMMC					
SD Card	1 microSD Card slot					
COM1	RS-422/485					
COM2	RS-232C					
Ethernet	10/100/1000 1 port			10/100/1000 2 ports		
USB Host	1 port					
Tool Port	1 USB Device					
Audio	Line-out 1 port					
Rated Voltage	24 VDC, Class2					
Inrush Current	30 A maximum					
Power Consumption	13 W (Max : 14 W)					
OS	Embedded Linux					
Project Memory	250 MB					
User Memory	4 GB					
Weight	510 g	950 g	510 g	950 g		
Real-Time Clock	Built-in					
Electronic buzzer	Built-in					
Dimension(mm)	185 x 127 x 51.9					
Panel Cut(mm)	177 x 119					
Certificate	UL	UL61010-1 / UL61010-2-201 (E231117)				
	CE	Electromagnetic Compatibility Directive 2014/30/EU (EMC)				
	FCC	The 47 CFR, Part2, Part15 and Part 18 Of FCC Requirement				
	KC	Registration of Broadcasting and Communication Equipments				
Protection Class	DE : IP66 / DF : IP68 (Front)					
	NEMA Type : 4X, 12 (Front)					
Supported Protocols	<b>Client Device (Ethernet):</b> Allen Bradley EtherNet/IP, ODVA EtherNet/IP, CIMON PLC (HMI Protocol), Fatek FBs, LSIS FEnet (XGI/XGK), Mitsubishi MELSEC Ethernet, Modbus TCP Master, OPC UA Client, Omron FINS, Proface GPEthernet, Siemens S7					
	<b>Client Device (Serial):</b> CIMON PLC (HMI Protocol), LSIS Cnet (XGI/XGK), Mitsubishi MELSEC Serial, Modbus RTU Master, Omron HostLink, Panasonic FP7, Yokogawa FA M3, Allen Bradley DF-1, Hallim Loader					
	<b>Server Device (Ethernet):</b> MQTT JSON Publisher, Modbus TCP Server, OPC UA Server, EtherNet/IP Server					
	<b>Server Device (Serial):</b> Modbus RTU Server					

## 6. 제품 사양

### ● eXT2-10W

Model	CM-eXT2-10W-R-DE	CM-eXT2-10W-C-DE	CM-eXT2-10W-R-DF	CM-eXT2-10W-C-DF	CM-eXT2-10W-RH-DF	CM-eXT2-10W-CH-DF
Enclosure	Front: Aluminum / Rear: Plastic		Front: Aluminum / Rear: Aluminum			
Display	10.1 inch Wide TFT Color					
Colors	16.7M					
Resolution	1280 x 800 WXGA (16:10)					
Effective Display Area	216.96 (H) x 135.60 (V) mm					
PPI	149					
Backlight Type	LED					
Luminance	500 cd/m <sup>2</sup>			1,200 cd/m <sup>2</sup>		
Contrast Ratio	800:1					
Backlight Life	50,000 hours					
Touch Panel	5 wire Resistive	10 points Capacitive	5 wire Resistive	10 points Capacitive	5 wire Resistive	10 points Capacitive
Touch Panel Accuracy	Active Area Length (X) ±2%, Width (Y) ±2%					
Display Orientation	Landscape (Standard, 180°), Portrait (90°, 270°)					
Memory	2GB LPDDR4					
Storage	8GB eMMC					
SD Card	1 microSD Card slot					
COM1	RS-422/485					
COM2	RS-232C					
Ethernet	10/100/1000 1 port			10/100/1000 2 ports		
USB Host	1 port					
Tool Port	1 USB Device					
Audio	-			Line-out 1 port		
Rated Voltage	24 VDC, Class2					
Inrush Current:	30 A maximum					
Power Consumption	15 W (Max: 16 W)			20W (Max: 21 W)		
OS	Embedded Linux					
Project Memory	250 MB					
User Memory	4 GB					
Weight	1.4 Kg			1.6 Kg		
Real-Time Clock	Built-in					
Electronic buzzer	Built-in					
Dimension(mm)	262.3 x 187.9 x 51.7(DE) / 262.3 x 187.9 x 51.6(DF)					
Panel Cut(mm)	254 x 179					
Certificate	UL					
	CE					
	FCC					
	KC					
Protection Class	Registration of Broadcasting and Communication Equipments					
	DE : IP66 / DF : IP68 (Front) NEMA Type : 4X, 12 (Front)					
Supported Protocols	Client Device (Ethernet): Allen Bradley EtherNet/IP, ODVA EtherNet/IP, CIMON PLC (HMI Protocol), Fatek FBs, LSIS FEnet (XGI/XGK), Mitsubishi MELSEC Ethernet, Modbus TCP Master, OPC UA Client, Omron FINS, Proface GPEthernet, Siemens S7					
	Client Device (Serial): CIMON PLC (HMI Protocol), LSIS Cnet (XGI/XGK), Mitsubishi MELSEC Serial, Modbus RTU Master, Omron HostLink, Panasonic FP7, Yokogawa FA M3, Allen Bradley DF-1, Hallim Loader					
	Server Device (Ethernet): MQTT JSON Publisher, Modbus TCP Server, OPC UA Server, EtherNet/IP Server					
	Server Device (Serial): Modbus RTU Server					

## 6. 제품 사양

### ● eXT2-12W

Model	CM-eXT2-12W-R-DE	CM-eXT2-12W-C-DE	CM-eXT2-12W-R-DF	CM-eXT2-12W-C-DF	CM-eXT2-12W-RH-DF	CM-eXT2-12W-CH-DF
Enclosure	Front: Aluminum / Rear: Plastic			Front: Aluminum / Rear: Aluminum		
Display	12.1 inch Wide TFT Color					
Colors	16.7M					
Resolution	1280 x 800 WXGA (16:10)					
Effective Display Area	261.12 (H) x 163.2 (V) mm					
PPI	125					
Backlight Type	LED					
Luminance	600 cd/m <sup>2</sup>			1,000 cd/m <sup>2</sup>		
Contrast Ratio	1000:1					
Backlight Life	50,000 hours					
Touch Panel	5 wire Resistive	10 points Capacitive	5 wire Resistive	10 points Capacitive	5 wire Resistive	10 points Capacitive
Touch Panel Accuracy	Active Area Length(X)±2%, Width(Y)±2%					
Display Orientation	Landscape (Standard, 180°), Portrait (90°, 270°)					
Memory	2GB LPDDR4					
Storage	8GB eMMC					
SD Card	-			1 microSD Card slot		
COM1	RS-422/485					
COM2	RS-232C					
Ethernet	10/100/1000 1 port			10/100/1000 2 ports		
USB Host	1 port					
Tool Port	1 USB Device					
Audio	-			Line-out 1 port		
Rated Voltage	24 VDC, Class2					
Inrush Current:	30 A maximum					
Power Consumption	21.2 W (Max: 22.7 W)			21.6 W (Max: 23 W)		
OS	Embedded Linux					
Project Memory	250 MB					
User Memory	4 GB					
Weight	2.2 Kg		2.4 Kg			
Real-Time Clock	Built-in					
Electronic buzzer	Built-in					
Dimension(mm)	314.9 x 221.2 x 53.6(DE) / 314.9 x 221.2 x 53.5(DF)					
Panel Cut(mm)	305 x 212					
Certificate	UL UL61010-1 / UL61010-2-201 (E231117)					
	CE Electromagnetic Compatibility Directive 2014/30/EU (EMC)					
	FCC The 47 CFR, Part2, Part15 and Part 18 Of FCC Requirement					
	KC Registration of Broadcasting and Communication Equipments					
Protection Class	DE : IP66 / DF : IP68 (Front) NEMA Type : 4X, 12 (Front)					
Supported Protocols	<b>Client Device (Ethernet):</b> Allen Bradley EtherNet/IP, ODVA EtherNet/IP, CIMON PLC (HMI Protocol), Fatek FBs, LSIS FEnet (XGI/XGK), Mitsubishi MELSEC Ethernet, Modbus TCP Master, OPC UA Client, Omron FINS, Proface GPEthernet, Siemens S7					
	<b>Client Device (Serial):</b> CIMON PLC (HMI Protocol), LSIS Cnet (XGI/XGK), Mitsubishi MELSEC Serial, Modbus RTU Master, Omron HostLink, Panasonic FP7, Yokogawa FA M3, Allen Bradley DF-1, Hallim Loader					
	<b>Server Device (Ethernet):</b> MQTT JSON Publisher, Modbus TCP Server, OPC UA Server, EtherNet/IP Server					
<b>Server Device (Serial):</b> Modbus RTU Server						

## 6. 제품 사양

### • eXT2-15W

Model	CM-eXT2-15W-R-DE	CM-eXT2-15W-C-DE	CM-eXT2-15W-R-DF	CM-eXT2-15W-C-DF	CM-eXT2-15W-RH-DF	CM-eXT2-15W-CH-DF
Enclosure	Front: Aluminum / Rear: Plastic		Front: Aluminum / Rear: Aluminum			
Display	15.6 inch Wide TFT Color					
Colors	16.7M					
Resolution	1920 x 1080 FHD (16:9)					
Effective Display Area	344.16 (H) x 193.59 (V) mm					
PPI	141					
Backlight Type	LED					
Luminance	450 cd/m <sup>2</sup>				1,200 cd/m <sup>2</sup>	
Contrast Ratio	800:1					
Backlight Life	50,000 hours					
Touch Panel	5 wire Resistive	10 points Capacitive	5 wire Resistive	10 points Capacitive	5 wire Resistive	10 points Capacitive
Touch Panel Accuracy	Active Area Length(X)±2%, Width(Y)±2%					
Display Orientation	Landscape (Standard, 180°), Portrait (90°, 270°)					
Memory	2GB LPDDR4					
Storage	8GB eMMC					
SD Card	-			1 microSD Card slot		
COM1	RS-422/485					
COM2	RS-232C					
Ethernet	10/100/1000 1 port			10/100/1000 2 ports		
USB Host	1 port					
Tool Port	1 USB Device					
Audio	-			Line-out 1 port		
Rated Voltage	24 VDC, Class2					
Inrush Current:	30 A maximum					
Power Consumption	23.5 W (Max: 25 W)				35 W (Max: 36.6 W)	
OS	Embedded Linux					
Project Memory	250 MB					
User Memory	4 GB					
Weight	3.2 Kg			3.4 Kg		
Real-Time Clock	Built-in					
Electronic buzzer	Built-in					
Dimension(mm)	394.2 x 248.5 x 53.6(DE) / 394.2 x 248.5 x 53.5(DF)					
Panel Cut(mm)	385 x 239					
Certificate	UL	UL61010-1 / UL61010-2-201 (E231117)				
	CE	Electromagnetic Compatibility Directive 2014/30/EU (EMC)				
	FCC	The 47 CFR, Part2, Part15 and Part 18 Of FCC Requirement				
	KC	Registration of Broadcasting and Communication Equipments				
Protection Class	DE : IP66 / DF : IP68 (Front) NEMA Type : 4X, 12 (Front)					
Supported Protocols	<b>Client Device (Ethernet):</b> Allen Bradley EtherNet/IP, ODVA EtherNet/IP, CIMON PLC (HMI Protocol), Fatek FBs, LSIS FEnet (XGI/XGK), Mitsubishi MELSEC Ethernet, Modbus TCP Master, OPC UA Client, Omron FINS, Proface GPEthernet, Siemens S7					
	<b>Client Device (Serial):</b> CIMON PLC (HMI Protocol), LSIS Cnet (XGI/XGK), Mitsubishi MELSEC Serial, Modbus RTU Master, Omron HostLink, Panasonic FP7, Yokogawa FA M3, Allen Bradley DF-1, Hallim Loader					
	<b>Server Device (Ethernet):</b> MQTT JSON Publisher, Modbus TCP Server, OPC UA Server, EtherNet/IP Server					
<b>Server Device (Serial):</b> Modbus RTU Server						

## 7. 환경 사양

항목	사양
사용 온도	DE : 0℃~65℃ / DF : -20℃~70℃
보관 온도	-25℃~75℃
사용 습도	상대습도 10%~90% (29℃ 이하, 이슬이 맺히지 않을 것)
보관 습도	상대습도 10%~90% (39℃ 이하, 이슬이 맺히지 않을 것)
환경 조건	700hPa~1114hPa(3000m 이하)
먼지	≤ 0.1mg/m <sup>3</sup> (도전성 먼지가 없을 것)
오염도	2 이하
주위 환경	부식성 가스, 먼지가 없을 것
내진동	JIS B 3502, IEC/EN61131-2 준거 5~9Hz 편진폭 : 3.5mm 9~150Hz 정가속도 : 9.8m/s <sup>2</sup> X,Y,Z 3 방향 10 사이클 (각 축당 약 100 분간)
내충격	JIS B 3502, IEC/EN61131-2 준거 147m/s <sup>2</sup> X,Y,Z 3 방향 각 ±3 회 (합계 18 회)
노이즈 저항도	Impulse, EFT/Burst, Surge, ±0.5KV
전자기 방전	4kV(접촉방전), 8kV(공기중방전) (IEC61000-4-2)

## 8. Xpanel 프로젝트 다운로드 방법

### ● PC 의 IP 확인

\* USB 케이블을 통한 프로젝트 다운로드 시 진행하지 않아도 됩니다.

PC 상에서 [시작] -> [실행]을 선택합니다.

입력 창에 "cmd"를 입력하고 [확인] 버튼을 누릅니다.

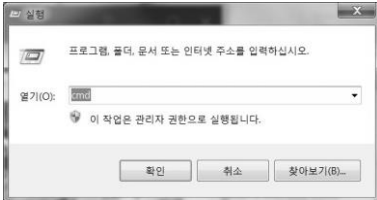

Command 창에 "ipconfig"를 입력하고 "Enter"를 입력합니다.

CIMON Canvas 가 설치된 PC 의 Ethernet 설정을 확인합니다.

```
C:\WINDOWS\system32>ipconfig

Windows IP Configuration

Ethernet adapter Ethernet:

    Connection-specific DNS Suffix  . : 
    Link-local IPv6 Address . . . . . : fe80::a560:1c23:1f32:3abb%14
    IPv4 Address. . . . . : 172.16.10.47
    Subnet Mask . . . . . : 255.255.0.0
    Default Gateway . . . . . : 172.16.10.1

C:\WINDOWS\system32>
```

## 8. Xpanel 프로젝트 다운로드 방법

### ● Xpanel의 IP 설정

\* USB 케이블을 통한 프로젝트 다운로드 시 진행하지 않아도 됩니다.

Control Center를 통해 Xpanel의 IP를 변경할 수 있습니다.

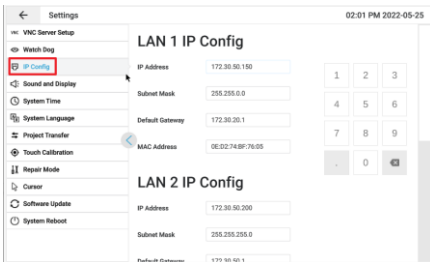
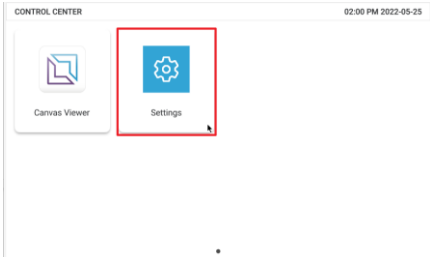

### ※ 설정 시 주의사항

- 1) Subnet Mask, Gateway는 반드시 PC와 동일하게 설정합니다.
- 2) Subnet Mask가 위와(255.255.0.0) 같은 경우 IP Address는 172.16.xxx.xxx와 같은 형태로 입력되어야 하며 다른 장비와 중복되지 않아야 합니다.
- 3) xxx는 0-255 사이의 숫자여야 합니다.

## 8. Xpanel 프로젝트 다운로드 방법

변경된 내용을 적용하고 저장하기 위해 [Apply and Save] 버튼을 선택합니다.

설정 내용이 적용되었다는 메시지가 표시됩니다.

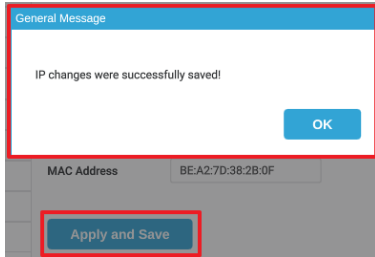

### ● 프로젝트 다운로드

CIMON Canvas 를 실행합니다.

다운로드 할 프로젝트를 열고 도구 메뉴의 [연결 설정]을 선택합니다.

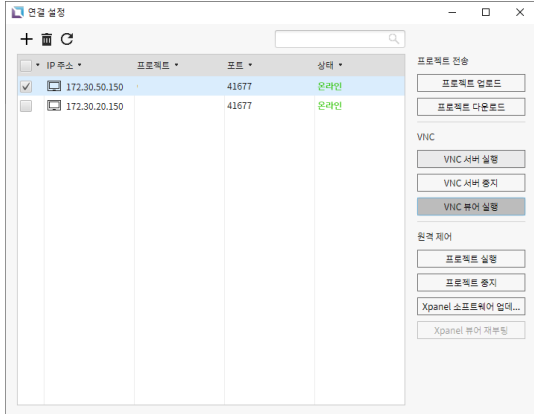

## 8. Xpanel 프로젝트 다운로드 방법

검색된 Xpanel 이 리스트에 표시됩니다.

프로젝트를 다운로드 할 Xpanel 을 선택하고 [프로젝트 다운로드]버튼을 클릭합니다.

USB 케이블을 통한 프로젝트 다운로드는 한 번에 한 대만 가능합니다.

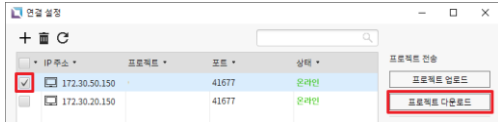

### ● 이동식 디스크로 프로젝트 다운로드(Xpanel → USB)

이동식 디스크를 PC 에 연결합니다. CIMON Canvas 프로젝트 파일 (.cnvs)을 PC 에 연결한 이동식 디스크에 복사합니다.

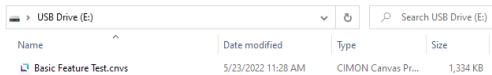

### ● 이동식 디스크에서 Xpanel 로 프로젝트 업데이트

프로젝트가 다운로드된 이동식디스크를 Xpanel 에 연결한 뒤 [Control Center] - [Settings] - [Project Transfer] 화면에서 연결한 이동식 디스크를 선택한 다음 [External Device -> Xpanel] 을 선택합니다.

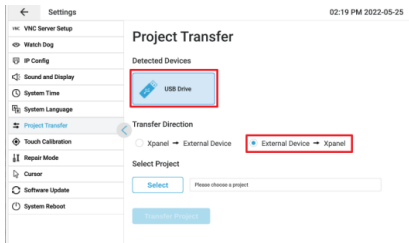

## 8. Xpanel 프로젝트 다운로드 방법

[Select Project]를 클릭한 뒤 나타나는 화면에서 외부 저장장치 내 프로젝트 파일을 선택합니다.

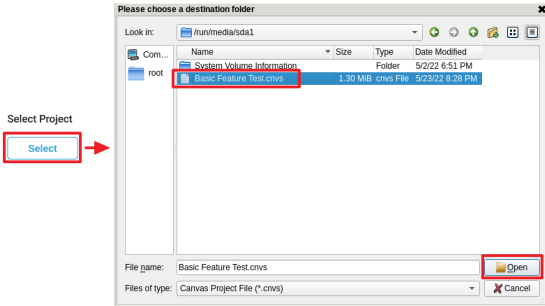

[Open]버튼을 눌러 창을 닫은 뒤 [Transfer Project] 버튼을 눌러 프로젝트를 복사합니다.

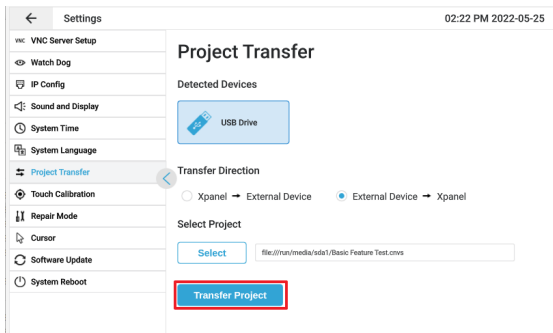

## 9. 품질보증규정

본 제품은 각종 국제 안전 규격에 의한 테스트를 철저히 수행하고 그에 따른 품질관리 및 전기용품 안전관리법에 의거하여 안전 인증을 받아 제조된 제품입니다. 또한 제조물 책임법에 따른 의무도 준수하였습니다. 본 제품은 (㈜싸이몬에서 보증하며, 고장 발생 시 아래의 보증규정에 의거하여 서비스를 받으실 수 있습니다.

### 제품 보증 규정

1. 본 제품의 설치와 사용방법에 관한 자세한 내용은 첨부된 설치안내서에 설명되어 있습니다. 보다 상세한 내용이 서술되어 있는 매뉴얼은 전자문서 형태로 인터넷을 이용하여 다운로드 가능하며, 대리점 또는 당사 영업 담당자에게 문의하시면 손쉽게 확보하실 수 있습니다.  
본 제품의 사용방법을 준수하지 않아서 생긴 피해나 위험은 당사에서 책임지지 않습니다.
2. 본 제품을 공급받은 후에 제조물에 결함이 존재하는 사실이 발견되면 즉시 당사에 알려주셔야 합니다. 이를 하지 않음으로써 발생하는 문제에 대해서는 당사에서 책임지지 않습니다.
3. 하드웨어, 소프트웨어 및 펌웨어를 포함한 모든 싸이몬 제품 (이하 '제품'으로 표기)의 보증기간은 출하일로부터 20개월입니다. 이 기간에 발생한 제품 하자 또는 제조 결함에 대해 당사는 해당 제품을 교환 또는 수리하여 드립니다. 구매 후 30일 이내 반송된 제품의 경우 당사의 보증 규정에 따라 리퍼 제품 또는 새 제품으로 교환될 수 있습니다. 수리 또는 교환된 제품에 대해서는 6개월 또는 원래 주어진 보증기간의 잔여 기간 중, 더 긴 기간을 보증 적용합니다.
4. 다음과 같은 경우에는 무상보증기간 내이라도 출장비, 부품비, 수리비등에 대하여 유상 서비스를 받게 됩니다. 또한 제품 보증이 적용되지 않습니다.
  - 1) 천재지변에 의한 고장 및 손상
  - 2) 타 업체가 수리하여 제품의 내용을 변경 또는 손상시킨 경우
  - 3) 허가된 (당사) A/S 요원에 의하지 않은 개봉, 수리, 변경 등의 경우
  - 4) 사용자의 부주의에 의한 고장 또는 손상
  - 5) 사용자의 임의 변경 사용 등에 의한 고장 또는 손상
  - 6) 전원장이나 연결 기기 장애로 발생한 고장 또는 손상
  - 7) 외부 충격이나 파손, 누수 등에 의한 고장 또는 손상
  - 8) 제품의 제조일자 또는 제품 일련번호가 제거되거나 훼손된 경우
  - 9) 인터넷 또는 기타 서비스를 통하여 제품에 전송되는 데이터나 콘텐츠에 대한 경우
  - 10) 당사 출하 시 과학, 기술 수준에서는 예상이 불가능한 사유에 의한 경우
5. 위 보증은 본 제품에 한하며 본 제품을 이용한 시스템 구성이나 응용 시에는 반드시 안정성을 사용자가 고려하여 사용해야 하며 본 제품을 적용한 응용 시스템은 책임지지 않습니다.

## MEMO

# CIMON Xpanel

In English

- CM-eXT2-07-R/C(H)-DE/DF
- CM-eXT2-10W-R/C(H)-DE/DF
- CM-eXT2-12W-R/C(H)-DE/DF
- CM-eXT2-15W-R/C(H)-DE/DF

# Xpanel

## CONTENTS

Essential Safety Precautions .....	31
General Safety Precautions .....	34
Package Contents .....	35
Dimensions .....	36
Interfaces .....	37
Installation .....	41
Wiring & Power Supply Cautions .....	43
Grounding Cautions .....	44
Specifications .....	45
Project Download .....	51
Product Warranty.....	56

- For your safety and the safe operation of this product, please read this manual before using the product. The manual is subject to change without notice.
- Please review the product specifications in this manual to determine the suitability of this product for its intended use.
- For your safety only qualified persons should perform electrical and wiring attachments to this product.
- This equipment has been tested and found to comply with the limits for a Class A digital device, pursuant to part 15 of the FCC Rules.

# Essential Safety Precautions



## Precautions for design

- Do not implement a trigger in the software for emergency stop of hazardous operation. If Xpanel is damaged while output signal remains ON or OFF, fatal accident may be caused. Design an emergency stop switch outside of the product so it can be manually stopped.
- Do not use Xpanel for the purpose of generating an alarm for injury to operators, breakdown of devices, or production halt.
- Design the system so that it can be hand-operated in case the product malfunctions.
- Do not use Xpanel as a control unit on applications requiring extreme stability such as airplane control device, aerospace device, centralized data processing device, nuclear control system, medical life support system, etc.
- In case Xpanel is used in transportations such as trains, vehicle, vessels, or warning devices for disasters and crime, various safety devices, and medical devices excluding life support system, you are required to design backup or failure provision system to secure reliability and stability.
- Even if the screen is black, the unit could still be turned on with a dead LCD backlight. When the operator touches a panel in this situation, the action could cause device's malfunction. Do not use this product for controlling safety devices such as emergency stop switches.

## Precautions for installation

- Please do not disassemble or modify the Xpanel. It will void the warranty and may cause an electric shock.
- This version of the Xpanel is not rated for flammable environments. Do not use this Xpanel around flammable gases. It may cause an explosion.

# Essential Safety Precautions



## Precautions for wiring

- Make sure to check if the device's power supply is turned off before wiring. Failure to do so may cause electric shock or damage to the device.
- Do not use power beyond the specified voltage range of the PC. Doing so may cause fire, electric shock or damage to the device.

## Maintenance

- The Xpanel uses a lithium battery to back up the internal clock. Do not replace this battery by yourself because it may cause an explosion. If the battery needs to be replaced, please contact your local service center.

## How to manage LCD breakage

- The LCD contains a powerful irritant and if for any reason the panel is damaged and this liquid contacts any part of your body, be sure to wash that area with running water for 15 minutes. If any of this liquid enters your eye, flush your eye for 15 minutes with running water and contact a physician.

# Essential Safety Precautions

## Cautions

### Precautions for installation

- Be sure to securely connect all cable connectors to the Xpanel. A loose connection may cause incorrect input or output.
- Make sure to install the unit vertically.

### Precautions for wiring

- Field Ground (FG) wires must be run individually from each unit to the master grounding terminal. DO NOT daisy chain the FG wires between devices.
- Correctly wire the Xpanel, be sure that the rated voltage and terminal layout are within the designated range. If the voltage supplied differs from the rated voltage, or incorrect wiring or grounding is performed, it may cause a fire or unit malfunction and it will void the warranty.
- Make sure to tighten the screw with standard torque (0.5~0.6Nm). Loose connections may cause short, fire or malfunction.
- Be careful that metal debris do not enter the Xpanel, they may cause a fire, Xpanel damage or malfunction.
- This product belongs to Overvoltage Category II.

### Precautions for unit disposal

- When this unit is disposed of, it should be done so according to your country's regulation for similar types of industrial waste.

## General Safety Cautions

- Do not strike the touch panel with a hard or pointed object, or press on the touch panel with too much force, since it may damage the touch panel or the display.
- Do not install the Xpanel where the ambient temperature exceeds the allowed range. Doing so may cause the Xpanel to malfunction or shorten product lifespan.
- Do not restrict or limit naturally occurring rear-face ventilation of the Xpanel, or storing or using the Xpanel in an environment that is too hot.
- Do not use the Xpanel in areas where large, sudden temperature changes can occur. These changes can cause condensation to form inside the unit, possibly causing the unit to malfunction.
- Do not allow water, liquids, metal or charged particles to enter inside the Xpanel, since they can cause either a Xpanel malfunction or an electrical shock.
- Do not store or use the Xpanel in direct sunlight, or in excessively dusty or dirty environments.
- Do not store or use the Xpanel where strong jolting or excessive vibration can occur.
- Do not store or use the Xpanel where chemicals (such as organic solvents, etc.) and acids can evaporate, or where chemicals and acids are present in the air.
- Do not use paint thinner or organic solvents to clean the Xpanel.
- Do not store or operate the LCD display in areas receiving direct sunlight, since the sun's UV rays may cause the LCD display's quality to deteriorate.
- After turning the Xpanel OFF, be sure to wait a few seconds before turning it ON again. If the Xpanel started too soon, it may not start up correctly.
- Due to the possibility of unexpected accidents, you must back up the project data of the Xpanel regularly.

## Package Contents

• The following items are contained in the package of the Xpanel. Before using the Xpanel, please confirm that all items listed here are present.

● Xpanel Unit - 1 EA

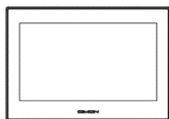

● Fastener - 4 EA (7"), 10 EA (10/12/15)

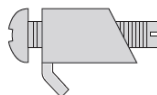

● 5-pin connector (RS-422/485) - 1 EA

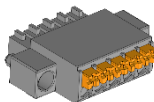

● Power plug - 1 EA

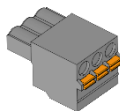

● Installation Guide - 1 EA



※ This unit has been carefully packed, with special attention to quality. However, should you find anything damaged or missing, please contact your local Xpanel distributor immediately.

# Dimensions

Unit: mm

· eXT2-07

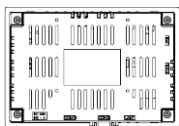
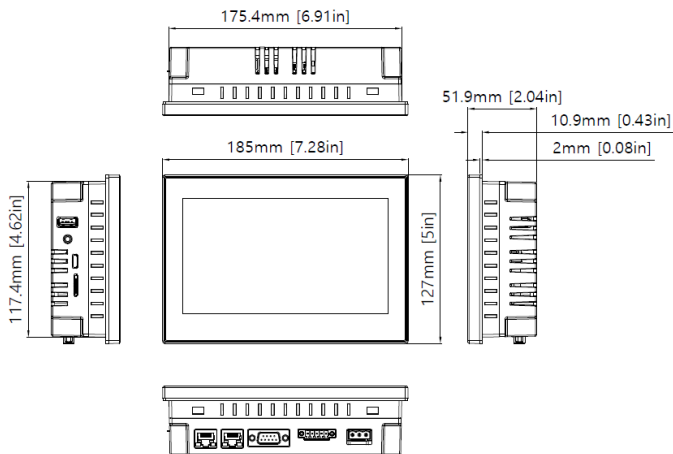

eXT2-07-R-DE

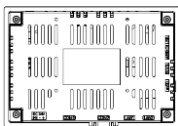

eXT2-07-R-DF

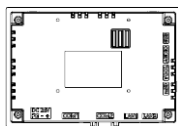

eXT2-07-C/CH/RH-DF

# Dimensions

Unit: mm

• eXT2-10W

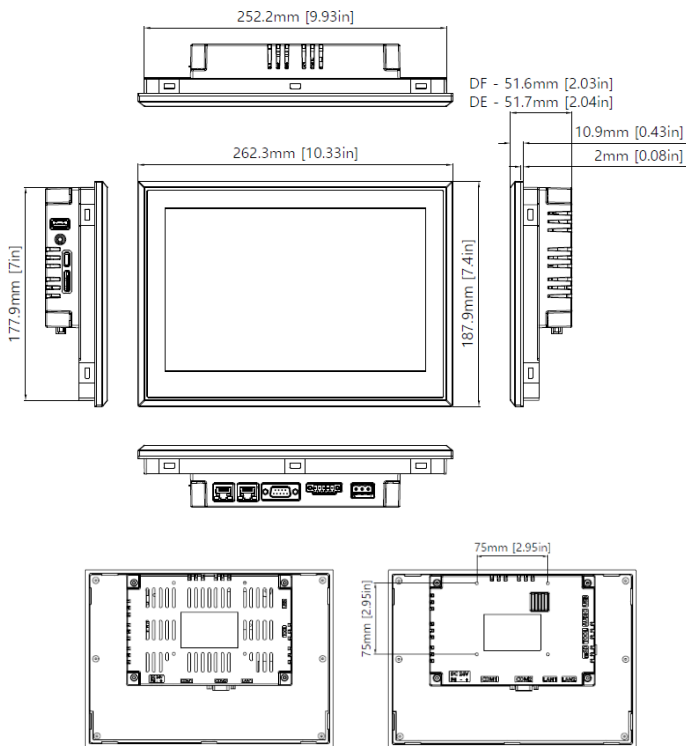

eXT2-10W-□□-DE

eXT2-10W-□□-DF

English

# Dimensions

Unit: mm

• eXT2-12W

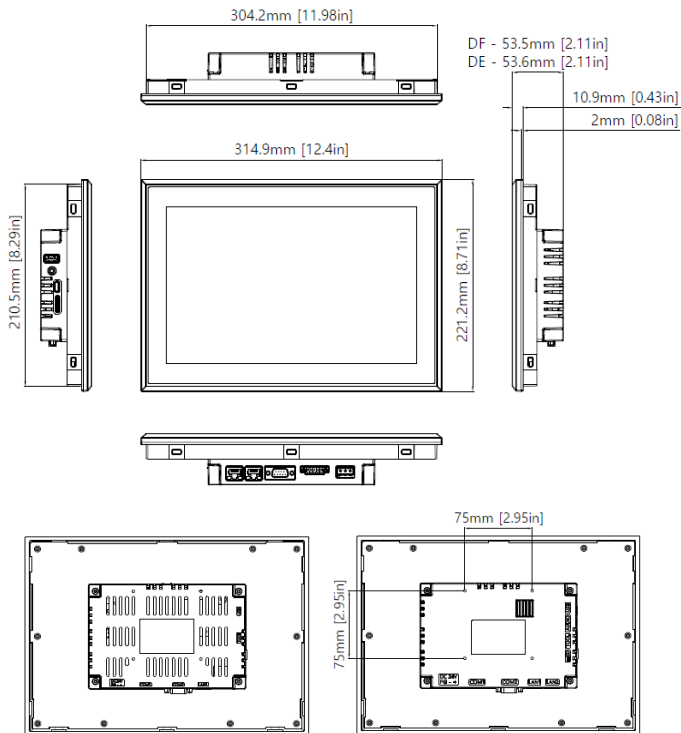

eXT2-12W-□□-DE

eXT2-12W-□□-DF

# Dimensions

Unit: mm

· eXT2-15W

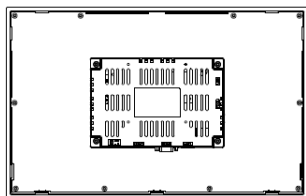
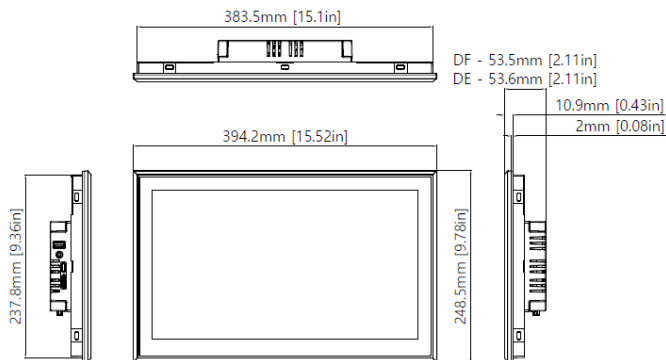

eXT2-15W-□□-DE

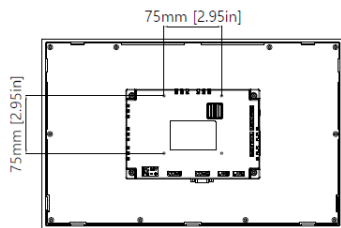

eXT2-15W-□□

English

## Interfaces

### · eXT2-□□-□□-DE

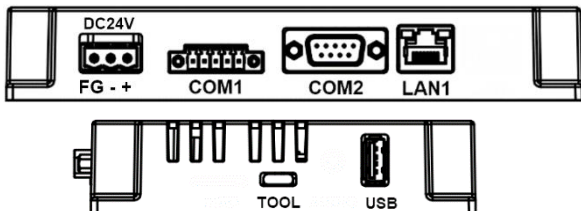

### · eXT2-□□-□□-DF

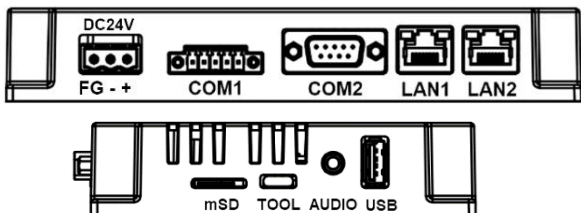

Name	Description
mSD	Micro SD Socket
TOOL	USB Device (USB 2.0 Type-C)
AUDIO	Audio Out (3.5mm Stereo)
USB	USB Host (USB 2.0 Type-A)

## Interfaces

### ● COM1: RS-422/485

This interface is used to connect between Xpanel and target device via an RS-422/485 cable.

Connector	Pin No.	Name	Description
	1	RDB	Receive Data B
	2	RDA	Receive Data A
	3	GND	Ground
	4	SDB	Send Data B
	5	SDA	Send Data A



- In case of RS-485 cable (2wire) connection, connect only both SDA and SDB lines.
- The RS-485 of the Xpanel runs under auto toggle mode.
- To reduce the risk of damaging the RS-422 circuit, be sure to connect the Pin 3(GND).

## Interfaces

### ● COM2: RS-232C

This interface is used for the connection between Xpanel and target device via an RS-232C cable.

Connector	Pin No.	Name	Description
	1		
	2	RD	Receive Data
	3	TD	Transmit Data
	4		
	5	SG	Signal Ground
	6		
	7	RTS	Request To Send
	8	CTS	Clear To Send
	9		



- Normal communication is not guaranteed when using USB connector as a communication port in ordinary times.
- Serial Port of the Xpanel is not insulated.
- SG (Signal Ground) and FG (Frame Ground) are connected in the Xpanel.
- Please be cautious not to short the circuit when connect external device to SG of the Xpanel.

# Interfaces

## ● Ethernet

This interface complies with the IEEE802.3 for Ethernet (10BaseT/100BaseTX).

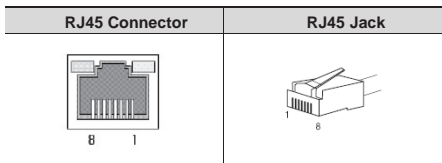

### Direct Cable: Host ↔ HUB

Cable	No	Color	Color	No	Cable
	1	Orange/W	Orange/W	1	
	2	Orange	Orange	2	
	3	Green/W	Green/W	3	
	4	Blue	Blue	4	
	5	Blue/W	Blue/W	5	
	6	Green	Green	6	
	7	Brown/W	Brown/W	7	
	8	Brown	Brown	8	

### Crossover Cable: Host ↔ Host

Cable	No	Color	Color	No	Cable
	1	Orange/W	Green/W	1	
	2	Orange	Green	2	
	3	Green/W	Orange/W	3	
	4	Blue	Blue	4	
	5	Blue/W	Blue/W	5	
	6	Green	Orange	6	
	7	Brown/W	Brown/W	7	
	8	Brown	Brown	8	

## Installation

- Create a panel cut and insert the Xpanel into the panel from the front.

Unit: mm

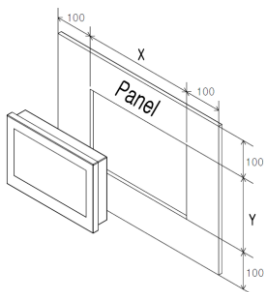

	X	Y
CM-eXT2-07	177	119
CM-eXT2-10W	254	179
CM-eXT2-12W	305	212
CM-eXT2-15W	385	239

- Attach the Installation Fasteners from inside of the panel. Insert each hook of fasteners into the slot and tighten it with a screwdriver.

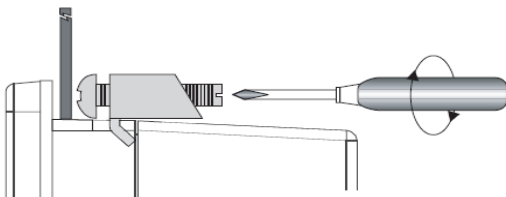

- Tightening the screws with too much force can damage the case of the Xpanel.
- The necessary torque is 0.5 N-m.
- Depending on the thickness of installation panel, the number of installation fasteners used may need to be increased to provide the desired level of moisture resistance.

# Installation

- For the performance and safe use of the equipment, please keep the distance between the back of the main unit and each all of the container at least 100 mm.

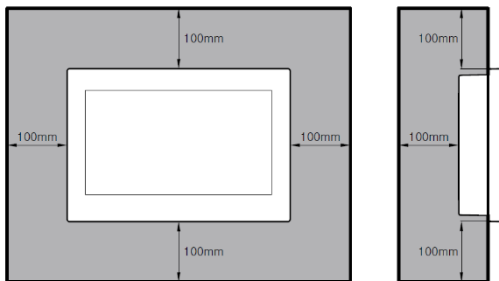

## ● VESA Mount Installation

### \* VESA Mount Supported Models

- CM-eXT2-07-C□□□
- CM-eXT2-07-RH-DF
- CM-eXT2-10W□□-DF
- CM-eXT2-12W□□-DF
- CM-eXT2-15W□□-DF

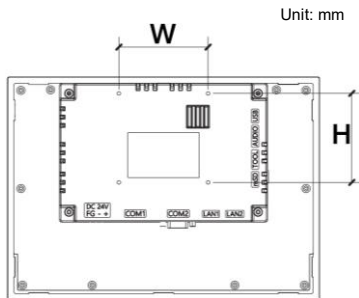

	H	W	Screw
VESA	75	75	M4 Max. 9

## Wiring & Power Supply Caution

### Warning

- Make sure to check if the device's power and external power supply is turned off before wiring, via a breaker, or similar unit. Failure to do so may cause electric shock or damage to the device.
- Check the rated voltage of the product.
- In case of terminal block connector type, make sure that power cord is connected properly.

### Connecting the Xpanel Power Cord

- If the power supply voltage exceeds the GP's specified range, connect a voltage transformer.
- Between the line and the ground, be sure to use a low noise power supply. If there is still an excessive amount of noise, connect a noise reducing transformer.
- The power supply cord should not be bundled with or kept close to main circuit lines (high voltage, high current), or input/output signal lines.
- Connect a surge absorber to handle power surges.
- To reduce noise, make the power cord as short as possible.
- When inputting power to the product, be sure to check the polarity (+, -) marked on the product before connecting. Incorrect polarity may cause product failure or fire.

### DC24V

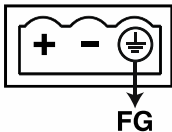

- To avoid a short caused by loose pin terminals, be sure to use pin terminals with an insulating sleeve.
- When the FG terminal is connected, be sure the wire is grounded. Not grounding the Xpanel unit will result in excess noise and vibration.
- The torque required to tighten these screws is 0.37\_0.44 lbf\*ft (0.5–0.6 N·m)
- Wire Range : AWG 14 - 26 SOL/STR, Wire Type : Cu

## Grounding Caution

- Inside the Xpanel unit, the SG (Signal Ground) and FG (Frame Ground) terminals are connected to each other.
- When grounding to the rear face FG terminal of the Xpanel, (on the Power Input Terminal Block), be sure to create an exclusive ground.
- When connecting an external device to the Xpanel with the SG terminal, ensure that no short-circuit loop is created when you setup the system.
- FG terminal is in the input power side. Connect the grounding cable to the 

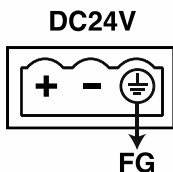

- Connect the FG terminal on the power supply to an exclusive ground. (Refer to the figure below)

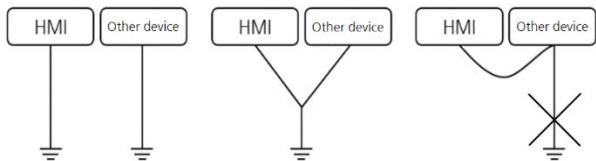

① Exclusive grounding : Good

② Common grounding : Adequate

③ Common grounding : Prohibited



- If the grounding causes operational errors, please detach the FG terminal.

## Specifications

# CM - eXT2 - 10W - RH - DF

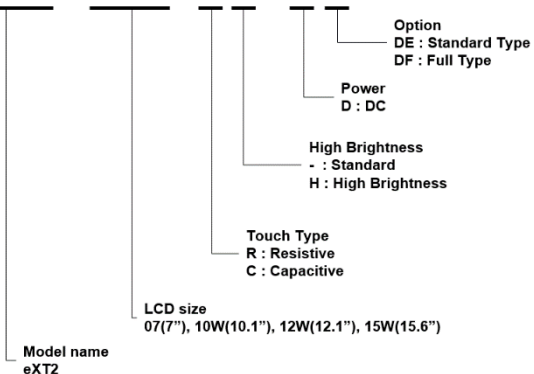

	Ethernet	Audio	MicroSD slot
- DE	1 port	X	X
- DF	2 port	O	O

# Specifications

## ● eXT2-07

Model	CM-eXT2-07-R-DE	CM-eXT2-07-R-DF	CM-eXT2-07-C-DF	CM-eXT2-07-RH-DF	CM-eXT2-07-CH-DF
Enclosure	Front / Rear: Plastic		Front / Rear: Aluminum		
Display	7 inch Wide TFT Color				
Colors	16.7M				
Resolution	1024 x 600 WSVGA (128:75)				
Effective Display Area	154.21 (H) x 85.92 (V) mm				
PPI	170				
Backlight Type	LED				
Luminance	1,000 cd/m <sup>2</sup>		1,200 cd/m <sup>2</sup>		
Contrast Ratio	1000:1				
Backlight Life	50,000 hours				
Touch Panel	4 wire Resistive	4 wire Resistive	10 points Capacitive	4 wire Resistive	10 points Capacitive
Touch Panel Accuracy	Active Area Length (X) ±2%, Width (Y) ±2%				
Display Orientation	Landscape (Standard, 180°), Portrait (90°, 270°)				
Memory	2GB LPDDR4				
Storage	8GB eMMC				
SD Card	1 microSD Card slot				
COM1	RS-422/485				
COM2	RS-232C				
Ethernet	10/100/1000 1 port	10/100/1000 2 ports			
USB Host	1 port				
Tool Port	1 USB Device				
Audio	-	Line-out 1 port			
Rated Voltage	24 VDC, Class2				
Inrush Current:	30 A maximum				
Power Consumption	13 W (Max : 14 W)				
OS	Embedded Linux				
Project Memory	250 MB				
User Memory	4 GB				
Weight	510 g		950 g		
Real-Time Clock	Built-in				
Electronic buzzer	Built-in				
Dimension(mm)	185 x 127 x 51.9				
Panel Cut(mm)	177 x 119				
Certificate	UL	UL61010-1 / UL61010-2-201 (E231117)			
	CE	Electromagnetic Compatibility Directive 2014/30/EU (EMC)			
	FCC	The 47 CFR, Part2, Part15 and Part 18 Of FCC Requirement			
	KC	Registration of Broadcasting and Communication Equipments			
Supported Protocols	Protection Class	DE : IP66 / DF : IP68 (Front) NEMA Type : 4X, 12 (Front)			
	Client Device (Ethernet):	Allen Bradley EtherNet/IP, ODVA EtherNet/IP, CIMON PLC (HMI Protocol), Fatek FBs, LSIS FEnet (XGI/XGK), Mitsubishi MELSEC Ethernet, Modbus TCP Master, OPC UA Client, Omron FINS, Proface GPEthernet, Siemens S7			
	Client Device (Serial):	CIMON PLC (HMI Protocol), LSIS Cnet (XGI/XGK), Mitsubishi MELSEC Serial, Modbus RTU Master, Omron HostLink, Panasonic FP7, Yokogawa FA M3, Allen Bradley DF-1, Hallim Loader			
	Server Device (Ethernet):	MQTT JSON Publisher, Modbus TCP Server, OPC UA Server, EtherNet/IP Server			
	Server Device (Serial):	Modbus RTU Server			

# Specifications

## • eXT2-10W

Model	CM-eXT2-10W-R-DE	CM-eXT2-10W-C-DE	CM-eXT2-10W-R-DF	CM-eXT2-10W-C-DF	CM-eXT2-10W-RH-DF	CM-eXT2-10W-CH-DF
Enclosure	Front: Aluminum / Rear: Plastic		Front: Aluminum / Rear: Aluminum			
Display	10.1 inch Wide TFT Color					
Colors	16.7M					
Resolution	1280 x 800 WXGA (16:10)					
Effective Display Area	216.96 (H) x 135.60 (V) mm					
PPI	149					
Backlight Type	LED					
Luminance	500 cd/m <sup>2</sup>			1,200 cd/m <sup>2</sup>		
Contrast Ratio	800:1					
Backlight Life	50,000 hours					
Touch Panel	5 wire Resistive	10 points capacitive	5 wire Resistive	10 points capacitive	5 wire Resistive	10 points capacitive
Touch Panel Accuracy	Active Area Length (X) ±2%, Width (Y) ±2%					
Display Orientation	Landscape (Standard, 180°), Portrait (90°, 270°)					
Memory	2GB LPDDR4					
Storage	8GB eMMC					
SD Card	1 microSD Card slot					
COM1	RS-422/485					
COM2	RS-232C					
Ethernet	10/100/1000 1 port			10/100/1000 2 ports		
USB Host	1 port					
Tool Port	1 USB Device					
Audio	-			Line-out 1 port		
Rated Voltage	24 VDC, Class2					
Inrush Current:	30 A maximum					
Power Consumption	15 W (Max: 16 W)			20W (Max: 21 W)		
OS	Embedded Linux					
Project Memory	250 MB					
User Memory	4 GB					
Weight	1.4 Kg			1.6 Kg		
Real-Time Clock	Built-in					
Electronic buzzer	Built-in					
Dimension(mm)	262.3 x 187.9 x 51.7(DE) / 262.3 x 187.9 x 51.6(DF)					
Panel Cut(mm)	254 x 179					
Certificate	UL					
	CE					
	FCC					
	KC					
Protection Class	Registration of Broadcasting and Communication Equipments					
	DE : IP66 / DF : IP68 (Front) NEMA Type : 4X, 12 (Front)					
Supported Protocols	<b>Client Device (Ethernet):</b> Allen Bradley EtherNet/IP, ODVA EtherNet/IP, CIMON PLC (HMI Protocol), Fatek FBs, LSIS FEnet (XGI/XGK), Mitsubishi MELSEC Ethernet, Modbus TCP Master, OPC UA Client, Omron FINS, Proface GPEthernet, Siemens S7					
	<b>Client Device (Serial):</b> CIMON PLC (HMI Protocol), LSIS Cnet (XGI/XGK), Mitsubishi MELSEC Serial, Modbus RTU Master, Omron HostLink, Panasonic FP7, Yokogawa FA M3, Allen Bradley DF-1, Hallim Loader					
	<b>Server Device (Ethernet):</b> MQTT JSON Publisher, Modbus TCP Server, OPC UA Server, EtherNet/IP Server <b>Server Device (Serial):</b> Modbus RTU Server					

# Specifications

## • eXT2-12W

Model	CM-eXT2-12W-R-DE	CM-eXT2-12W-C-DE	CM-eXT2-12W-R-DF	CM-eXT2-12W-C-DF	CM-eXT2-12W-RH-DF	CM-eXT2-12W-CH-DF
Enclosure	Front: Aluminum / Rear: Plastic			Front: Aluminum / Rear: Aluminum		
Display	12.1 inch Wide TFT Color					
Colors	16.7M					
Resolution	1280 x 800 WXGA (16:10)					
Effective Display Area	261.12 (H) x 163.2 (V) mm					
PPI	125					
Backlight Type	LED					
Luminance	600 cd/m <sup>2</sup>				1,000 cd/m <sup>2</sup>	
Contrast Ratio	1000:1					
Backlight Life	50,000 hours					
Touch Panel	5 wire Resistive	10 points capacitive	5 wire Resistive	10 points capacitive	5 wire Resistive	10 points capacitive
Touch Panel Accuracy	Active Area Length(X)±2%, Width(Y)±2%					
Display Orientation	Landscape (Standard, 180°), Portrait (90°, 270°)					
Memory	2GB LPDDR4					
Storage	8GB eMMC					
SD Card	-			1 microSD Card slot		
COM1	RS-422/485					
COM2	RS-232C					
Ethernet	10/100/1000 1 port			10/100/1000 2 ports		
USB Host	1 port					
Tool Port	1 USB Device					
Audio	-			Line-out 1 port		
Rated Voltage	24 VDC, Class2					
Inrush Current:	30 A maximum					
Power Consumption	21.2 W (Max: 22.7 W)				21.6 W (Max: 23 W)	
OS	Embedded Linux					
Project Memory	250 MB					
User Memory	4 GB					
Weight	2.2 Kg			2.4 Kg		
Real-Time Clock	Built-in					
Electronic buzzer	Built-in					
Dimension(mm)	314.9 x 221.2 x 53.6(DE) / 314.9 x 221.2 x 53.5(DF)					
Panel Cut(mm)	305 x 212					
Certificate	UL UL61010-1 / UL61010-2-201 (E231117)					
	CE Electromagnetic Compatibility Directive 2014/30/EU (EMC)					
	FCC The 47 CFR, Part2, Part15 and Part 18 Of FCC Requirement					
	KC Registration of Broadcasting and Communication Equipments					
Protection Class	DE : IP66 / DF : IP68 (Front) NEMA Type : 4X, 12 (Front)					
Supported Protocols	<b>Client Device (Ethernet):</b> Allen Bradley EtherNet/IP, ODVA EtherNet/IP, CIMON PLC (HMI Protocol), Fatek FBs, LSIS FEnet (XGI/XGK), Mitsubishi MELSEC Ethernet, Modbus TCP Master, OPC UA Client, Omron FINS, Proface GPEthernet, Siemens S7					
	<b>Client Device (Serial):</b> CIMON PLC (HMI Protocol), LSIS Cnet (XGI/XGK), Mitsubishi MELSEC Serial, Modbus RTU Master, Omron HostLink, Panasonic FP7, Yokogawa FA M3, Allen Bradley DF-1, Hallim Loader					
	<b>Server Device (Ethernet):</b> MQTT JSON Publisher, Modbus TCP Server, OPC UA Server, EtherNet/IP Server					
	<b>Server Device (Serial):</b> Modbus RTU Server					

# Specifications

## • eXT2-15W

Model	CM-eXT2-15W-R-DE	CM-eXT2-15W-C-DE	CM-eXT2-15W-R-DF	CM-eXT2-15W-C-DF	CM-eXT2-15W-RH-DF	CM-eXT2-15W-CH-DF
Enclosure	Front: Aluminum / Rear: Plastic		Front: Aluminum / Rear: Aluminum			
Display	15.6 inch Wide TFT Color					
Colors	16.7M					
Resolution	1920 x 1080 FHD (16:9)					
Effective Display Area	344.16 (H) x 193.59 (V) mm					
PPI	141					
Backlight Type	LED					
Luminance	450 cd/m <sup>2</sup>				1,200 cd/m <sup>2</sup>	
Contrast Ratio	800:1					
Backlight Life	50,000 hours					
Touch Panel	5 wire Resistive	10 points capacitive	5 wire Resistive	10 points capacitive	5 wire Resistive	10 points capacitive
Touch Panel Accuracy	Active Area Length(X)±2%, Width(Y)±2%					
Display Orientation	Landscape (Standard, 180°), Portrait (90°, 270°)					
Memory	2GB LPDDR4					
Storage	8GB eMMC					
SD Card	-			1 microSD Card slot		
COM1	RS-422/485					
COM2	RS-232C					
Ethernet	10/100/1000 1 port		10/100/1000 2 ports			
USB Host	1 port					
Tool Port	1 USB Device					
Audio	-			Line-out 1 port		
Rated Voltage	-D: DC24V, Class2					
Inrush Current:	30 A maximum					
Power Consumption	23.5 W (Max: 25 W)				35 W (Max: 36.6 W)	
OS	Embedded Linux					
Project Memory	250 MB					
User Memory	4 GB					
Weight	3.2 Kg		3.4 Kg			
Real-Time Clock	Built-in					
Electronic buzzer	Built-in					
Dimension(mm)	394.2 x 248.5 x 53.6(DE) / 394.2 x 248.5 x 53.5(DF)					
Panel Cut(mm)	385 x 239					
Certificate	UL UL61010-1 / UL61010-2-201 (E231117)					
	CE Electromagnetic Compatibility Directive 2014/30/EU (EMC)					
	FCC The 47 CFR, Part2, Part15 and Part 18 Of FCC Requirement					
	KC Registration of Broadcasting and Communication Equipments					
Protection Class	DE : IP66 / DF : IP68 (Front) NEMA Type : 4X, 12 (Front)					
Supported Protocols	<b>Client Device (Ethernet):</b> Allen Bradley EtherNet/IP, ODVA EtherNet/IP, CIMON PLC (HMI Protocol), Fatek FBs, LSIS FEnet (XGI/XGK), Mitsubishi MELSEC Ethernet, Modbus TCP Master, OPC UA Client, Omron FINS, Proface GP Ethernet, Siemens S7					
	<b>Client Device (Serial):</b> CIMON PLC (HMI Protocol), LSIS Cnet (XGI/XGK), Mitsubishi MELSEC Serial, Modbus RTU Master, Omron HostLink, Panasonic FP7, Yokogawa FA M3, Allen Bradley DF-1, Hallim Loader					
	<b>Server Device (Ethernet):</b> MQTT JSON Publisher, Modbus TCP Server, OPC UA Server, EtherNet/IP Server					
<b>Server Device (Serial):</b> Modbus RTU Server						

## Specifications

Item	Description
<b>Operating Temperature</b>	DE : 0°C–65°C / DF : -20°C–70°C
<b>Storage Temperature</b>	-25°C–75°C
<b>Operating Humidity</b>	10–90% RH (below 29°C, not condensed)
<b>Storage Humidity</b>	10–90% RH (below 39°C, not condensed)
<b>Altitude (Air Pressure)</b>	700–1114 hPa (3000 m / 9800 ft or less)
<b>Dust Exposure Allowance</b>	$\leq 0.1 \text{ mg/m}^3$
<b>Pollution Degree</b>	$\leq 2$
<b>Corrosion Immunity</b>	No corrosive gas and dust
<b>Vibration Protection</b>	JIS B 3502, IEC/EN 61131-2 compliant 5–9 Hz Single amplitude: 3.5 mm 9–150 Hz Fixed acceleration: $9.8 \text{ m/s}^2$ X,Y,Z directions for 10 cycles (approx. 100 min)
<b>Shock Protection</b>	JIS B 3502, IEC/EN 61131-2 compliant $147 \text{ m/s}^2$ , X,Y,Z directions for $\pm 3$ times (Total 18 times)
<b>Noise Protection</b>	Impulse, EFT/Burst, Surge, $\pm 0.5 \text{ KV}$
<b>Electrostatic Discharge</b>	Contact Discharge 4 kV (IEC 61000-4-2)
	Air Discharge 8 kV (IEC 61000-4-2)

# Project Download

- **Check IP address of PC**

\* **This step is not required for project download via USB cable.**

Go to [Window] – [Run] and enter 'cmd' on the input screen.

Enter 'ipconfig' on the command screen to check the PC's Ethernet setup.

```
C:\Users#\ >ipconfig
Windows IP Configuration

Ethernet adapter 이더넷:

    Connection-specific DNS Suffix . : 
    Link-local IPv6 Address . . . . . : fe80::522:544d:7045:df08%2
    IPv4 Address. . . . . : 172.30.10.121
    Subnet Mask . . . . . : 255.255.0.0
    Default Gateway . . . . . : 172.30.10.1
```

- **IP setting in Control Center**

\* **This step is not required for project download via USB cable.**

In the Control Center, you can change the IP setting of Xpanel.

Port 1 is assigned to the upper port, and Port 2 is assigned to the bottom port.

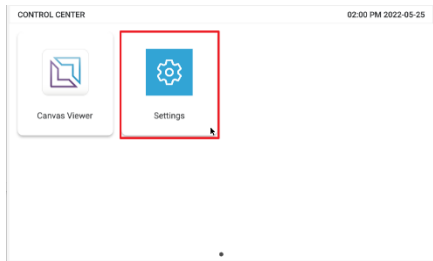

# Project Download

Select 'IP config' button in the Xpanel Manager.

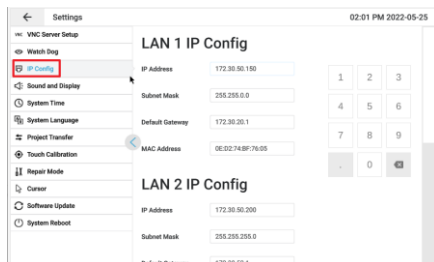

Enter the IP address, Subnet mask, and gateway in each field.

Tap 'Apply and Save' button to apply the network settings.

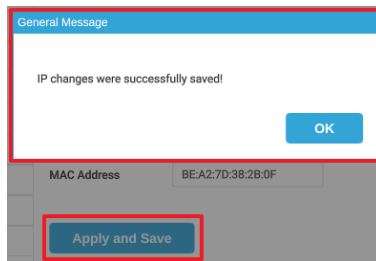

※ Please note that all the ports must not be configured on the same subnet mask.

## ※ NOTICE

- 1) Subnet Mask, Gateway should match those of PC.
- 2) If the subnet mask is 255.255.0.0, for example in this image, the IP address should look like 192.168.xxx.xxx and should not be duplicated to any other devices.
- 3) xxx must be in range of 0-255.

# Project Download

## • Project Download

Run CIMON Canvas and open the project.

Go to [Tools] – [Connection Setup].

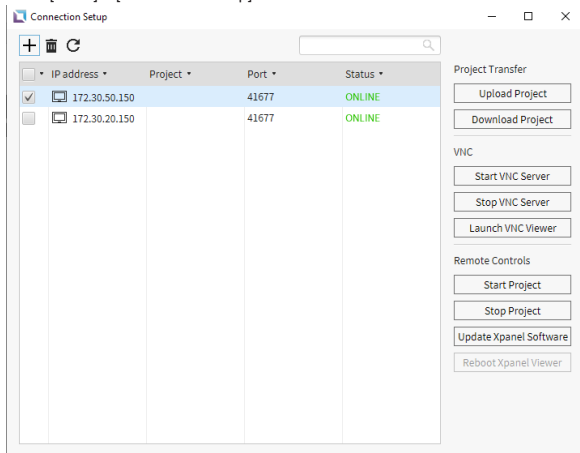

Select the target Xpanel from the list and press [Download Project].

While using USB cable for project download, only one device per connection is available.

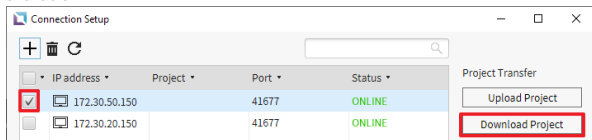

# Project Download

- **Download project to the Removable Disk (Xpanel → USB)**

Connect a removable disk to the PC and move the CIMON Canvas project file (.cnvs) to the removable disk.

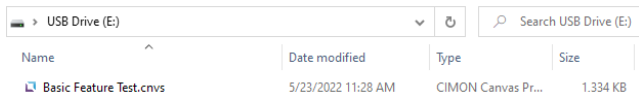

Name	Date modified	Type	Size
Basic Feature Test.cnvs	5/23/2022 11:28 AM	CIMON Canvas Pr...	1,334 KB

- **Upload the project from removable disk to Xpanel**

Connect the removable disk to the Xpanel. Select [Settings] – [Project Transfer] in the Control Center. Select the device where the project is saved then select [External Device -> Xpanel].

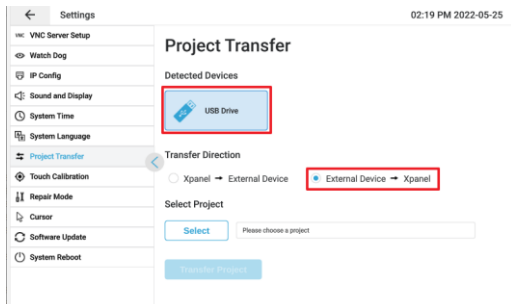

# Project Download

Click [Select Project] and select the project file in the removable device.

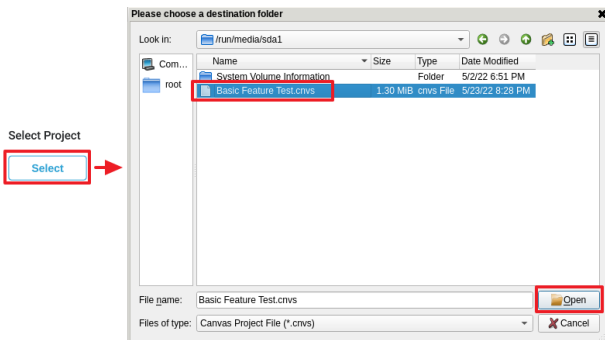

Press the [Open] button to finish the selection and then press [Transfer Project] button to copy the project.

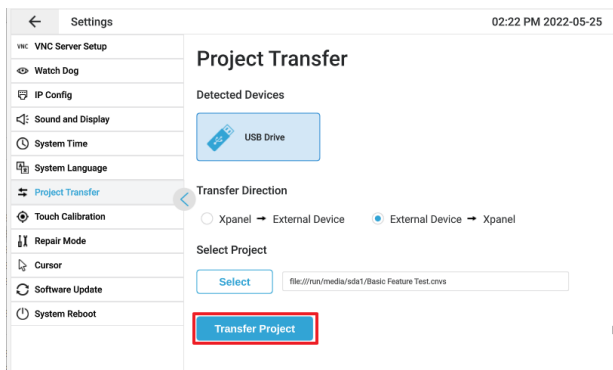

## Products Warranty

All CIMON products, including hardware, software, and firmware (collectively called "Products"), carry a **three-year warranty** against defects in materials and workmanship beginning from the date of product shipment from CIMON to its appointed distributor. If a product proves defective in materials and workmanship within three years from purchase, we will replace or repair it. **Products returned under warranty after 30 days may be replaced with refurbished or manufactured goods at CIMON's discretion.** CIMON makes no representation or warranty, express or implied, that the operation of the Products will be uninterrupted or error-free or that the functions contained therein will meet or satisfy the buyer's intended use or requirements.

**Repaired or replaced Products provided as a result of this warranty are warranted for 90 days from the shipment to the buyer or the remainder of the original warranty term for that particular product, whichever is longer.** CIMON's standard policy is that all customers are responsible for freight charges to CIMON when returning products under the warranty return policy.

This warranty will be void if the Products date codes, serial numbers, or seals are removed or defaced. Warranties do not apply to products that have been subjected to abnormal use, abnormal conditions, improper storage, exposure to moisture or dampness, unauthorized modifications, unauthorized repair, misuse, neglect, accident, alteration, improper installation, or other acts that are not the fault of CIMON, including damage caused in shipping. Our warranty also does not apply to any product that has been damaged by external causes such as fire, flood, sand, dirt, lightning, acts of God, battery leakage, theft, blown fuses, improper use of any electrical source or connection to Products, not recommended in writing for interconnection by CIMON.

In no event will CIMON be liable, whether in contract, tort, or under any other legal theory, for lost profits or revenues, loss of use, or similar economic loss for any indirect, special, incidental, consequential, punitive, or similar damages arising out of or in connection with any Products, including non-conforming Products, or for any third-party claims against you relating to the Products, even if we have been advised of the possibility of such a claim. **In no event will our monetary liability concerning any Products exceed the purchase price you paid them.**

To minimize the risk of potential safety problems, you should follow all applicable local and national codes that regulate the installation and operation of your equipment. These codes vary from area to area and usually change with time. It is your responsibility to determine which codes should be followed and to verify that the equipment, installation, and operation comply with the latest revision of these codes.

## Products Warranty

**All CIMON products, including hardware, software, and firmware (collectively called "Products") license disclaimer and limitation of warranties.**

YOUR USE OF ANY CIMON PRODUCTS AND CONTENT ACCESSIBLE THROUGH THE PRODUCTS IS ENTIRELY AT YOUR OWN RISK. EXCEPT AS DESCRIBED IN THIS AGREEMENT, THE PRODUCTS ARE PROVIDED "AS IS." TO THE MAXIMUM EXTENT PERMITTED BY APPLICABLE LAW, CIMON, ITS AFFILIATES, AND ITS THIRD-PARTY SERVICE OR DATA PROVIDERS, LICENSORS, DISTRIBUTORS, OR SUPPLIERS (COLLECTIVELY REFERRED TO AS "SUPPLIERS") DISCLAIM ALL WARRANTIES, EXPRESS OR IMPLIED, INCLUDING ANY WARRANTY THAT THE PRODUCTS ARE FIT FOR A PARTICULAR PURPOSE, TITLE, MERCHANTABILITY, DATA LOSS, NON-INTERFERENCE WITH OR NON-INFRINGEMENT OF ANY INTELLECTUAL PROPERTY RIGHTS, OR THE ACCURACY, RELIABILITY, QUALITY OR CONTENT IN OR LINKED TO THE PRODUCTS.

CIMON, ITS AFFILIATES, AND SUPPLIERS DO NOT WARRANT THAT THE PRODUCTS ARE SECURE AND FREE FROM BUGS, VIRUSES, INTERRUPTION, ERRORS, THEFT, OR DESTRUCTION. FURTHER, CIMON DOES NOT WARRANT ACCESS TO THE INTERNET OR ANY OTHER SERVICE, CONTENT, OR DATA TRANSMITTED THROUGH THE PRODUCTS. IF THE EXCLUSIONS FOR IMPLIED WARRANTIES DO NOT APPLY TO YOU, ANY IMPLIED WARRANTIES ARE LIMITED TO 60 DAYS FROM THE DATE OF PURCHASE OR DELIVERY OF THE PRODUCTS, WHICHEVER IS SOONER. EQUIPMENT DAMAGE OR SERIOUS INJURY TO PERSONNEL, INCLUDING DEATH, CAN RESULT FROM THE FAILURE TO FOLLOW ALL APPLICABLE CODES AND STANDARDS, INCLUDING ENGINEERING STANDARDS. CIMON DOES NOT ASSUME ANY RESPONSIBILITY FOR YOUR PRODUCT DESIGN, INSTALLATION OR OPERATION.

CIMON, ITS AFFILIATES, AND SUPPLIERS DISCLAIM ANY REPRESENTATIONS OR WARRANTIES THAT YOUR USE OF THE PRODUCTS WILL SATISFY OR ENSURE COMPLIANCE WITH ANY LEGAL OBLIGATIONS, LAWS, OR REGULATIONS. LIMITATION OF LIABILITY AND INDEMNITY: TO THE MAXIMUM EXTENT PERMITTED BY APPLICABLE LAW, THE ENTIRE LIABILITY OF CIMON, ITS AFFILIATES, AND SUPPLIERS FOR ALL MATTERS OR CLAIMS RELATING TO THIS AGREEMENT SHALL BE LIMITED TO THE AMOUNT YOU PAID FOR THE PRODUCTS DURING THE TWELVE (12) MONTHS BEFORE SUCH CLAIM. THE STATUTE OF LIMITATIONS FOR FILING A CLAIM SHALL BE LIMITED TO THE SHORTER OF TWELVE MONTHS OR THE SHORTEST PERIOD ALLOWED UNDER APPLICABLE LAW.

## Products Warranty

SUBJECT TO APPLICABLE LAW, CIMON, ITS AFFILIATES, AND SUPPLIERS ARE NOT LIABLE FOR ANY OF THE FOLLOWING: (A) INDIRECT, SPECIAL, INCIDENTAL, PUNITIVE OR CONSEQUENTIAL DAMAGES; (B) DAMAGES RELATING TO FAILURES OF TELECOMMUNICATIONS, THE INTERNET, ELECTRONIC COMMUNICATIONS, CORRUPTION, SECURITY, LOSS OR THEFT OF DATA, VIRUSES, SPYWARE, LOSS OF BUSINESS, REVENUE, PROFITS OR INVESTMENT, OR USE OF SOFTWARE OR HARDWARE THAT DOES NOT MEET CIMON SYSTEM REQUIREMENTS. THE ABOVE LIMITATIONS APPLY EVEN IF CIMON AND ITS AFFILIATES AND SUPPLIERS HAVE BEEN ADVISED OF THE POSSIBILITY OF SUCH DAMAGES AND/OR THE POSSIBILITY OF DAMAGES GREATER THAN THE LIMITATION ABOVE. THIS AGREEMENT SETS FORTH THE ENTIRE LIABILITY OF CIMON, ITS AFFILIATES, AND YOUR EXCLUSIVE REMEDY CONCERNING THE SOFTWARE AND ITS USE. THE PARTIES FURTHER AGREE THAT THE APPLICABLE LAW AND VENUE FOR ANY DISPUTE ARE THE LAWS OF NEVADA. TO THE EXTENT ALLOWED BY APPLICABLE LAW, ANY CLAIMS SHALL BE BROUGHT IN HENDERSON, NEVADA, AND NEVADA LAW SHALL APPLY.

## MEMO

## MEMO

## 고객서비스 정보

- 회 사 명: (주)싸이몬 CIMON CO.,Ltd
- 홈페이지: [www.cimon.co.kr](http://www.cimon.co.kr)
- A / S: 경기도 용인시 수지구 포은대로 59 번길 40 (상현동 1187)  
시그니처광교 2 차 지식산업센터 805 호
- 전 화: 1899-1891
- 팩 스: 031-216-4789
- 담 당: 품질보증팀 팀장
- 이 메 일: [cs@cimon.com](mailto:cs@cimon.com)

## CIMON CO., LTD

### Korea Address

#805 Office Bld., Signature Gwang-gyo2  
40, Poeun-daero 59beon-gil, Suji-gu, Yongin-si, Gyeonggi-do,  
Republic of Korea 16864  
Tel. +82-31-780-1039

### USA Address

CIMON Inc. 2435 W. Horizon Ridge Pkwy, #100, Henderson,  
NV 89052  
Tel. +1-702-820-1060  
Homepage : [www.cimon.com](http://www.cimon.com)